

Operation Manual

PH5000 / PH5500

pH/ORP Controller / Transmitter

Preface

This manual serves to explain the use of CLEAN PH5000 / PH5500 Controller / Transmitter. This operation manual is written to cover as many anticipated applications of PH5000 / PH5500 controller / transmitter. If you have any doubts in the use of the instruments, please do not hesitate to contact CLEAN local customer service center.

The information written in this manual is subject to change without prior notice as improvements are made, and does not represent a commitment of CLEAN brand from CLEAN Instruments.

CLEAN Instruments. can not accept any responsibility for damage or malfunction of the unit due to improper use of the instrument.

©2009 CLEAN Instruments - CISC. All rights reserved.

Safety Information

CLEAN PH5000 / PH5500 Controller / Transmitter should be installed and operated only in the manner specified in the operation manual. Only skilled, trained or authorized person should carry out installation, setup and operation of the instrument.

Before powering up the unit, make sure that power source is connected as specified in the top label. Failure to do so may result in a permanent damage to the unit.



Protect level against electric shock mainly depends on relevant installation rules.

TABLE OF CONTENTS

1	PREFACE	1
	Before Use	1
	In Use	1
	Safety Measures	2
2	PRODUCT DESCRIPTION	3
2.1	Description Of Instrument Speciality	3
2.2	Measurement And Control System	4
2.3	Appearance	5
2.3.1	Display Introduction	6
2.3.2	Key Instruction	7
2.3.3	LED Instruction	7
2.3.4	Password	7
2.3.5	Function Preview	7
3	INSTALLATION AND ACCESSORY	9
	Installation	9
	PH5000 Connetion Diagram	10
	PH5500 Connetion Diagram	11
	Measurement Mode	12
4	CALIBRATION MODE	13
4.1	Entering Calibration Mode	13
4.2	pH Calibration	14
4.3	ORP-mV Calibration	16
5	SET UP MODE	17
	ENTERING SET UP MODE	17
5.1	P01: Temperature Set-Up Function	18
5.2	P02: Offset Set-Up Function	20
5.3	P03: Output Current (SP1/SP2) Function	21
5.4	P04: Control Mode Function	22
5.5	P05: Relay 1 Set-Up Function	23
5.6	P06: Relay 2 Set-Up Function	25
5.7	P07: Alarm Relay 3 Set-Up Function	27
5.8	P08: pH/ORP Electrode Selection, Buffer Selection And Digit Filter Function	29
5.9	P09: Transmitting Rate Function	31
5.10	P10: Reverting To Factory Default Settings	32
5.11	Communication Protocol	33
6	TECHNICAL PARAMETERS	36
6.1	Technical Parameters Form	36
6.2	Parameter Setting And Factory Default Setting	37
7	GENERAL INFORMATION	38
	Warranty	38
	Returning the Items	38
	Guidelines for Returning the Items	38
	Appendix 2 – pH Temperature Corresponding To pH Buffer Solution	39
	Appendix 3 – Hysteresis Band	40
	Appendix 4 – Control Movement	41
	Accessory 5 – Abbreviations In Function Menu	43



1 PREFACE

BEFORE USE

Thank you for selecting CLEAN PH5000 / PH5500 pH/ORP Controller and Transmitter.

Although PH5000 / PH5500 pH/OPR Controller / Transmitter use advanced technology and meet the requirements of current safety rules, improper use can still threaten the safety of users, and / or cause harmful influences to factory and other equipments. Therefore, before using pH/ORP controller / transmitter, relevant person must read and understand contents of this operation manual.

Following symbols used in this operation manual are to distinguish safety measures and appendix information:

	This symbol means contents and safety measures and warning of potential dangers. If they are neglected, people may be hurted and property may be damaged.
	This symbol indicates the useful tips that ease your meter operation.

Operation manual should be kept accessible within the person who use pH/ORP controllers / transmitters.

If you have problems which are not mentioned or can not be explained in this manual, please contact CLEAN local customer service center. They will be very glad to help you.



IN USE

On any unmentioned use or the use that contradict with the technical parameters the operators should bear the responsibility.

Other conditions of right use include:

- Remarks and requirements stated in operation manual.
- Local safety regulations on safe operation.
- Information and warning of products that are used together with the transmitters in the contract. (chassis, electrode, etc.)
- Required operating environment and working condition.

SAFETY MEASURES

	pH / ORP transmitters may only be carried out by trained experts.
	Unqualified Transmitters should not be installed and used.
	pH / ORP transmitters should be used under the required working condition.
	pH / ORP transmitters should not be opened and repaired by clients themselves.
	Modified pH / ORP transmitters should not be used. Manufacturers and suppliers do not bear responsibility for the damage and lost caused by modifying instruments without permission. Clients should bear all the risks.
This instrument is IP65 rated. Please use waterproof cable glands when you connect the cable. Also, please loose it when you open the cover. After connecting the cable, please tighten the cable conductor according to the following instruction with cable ties, or it will cause danger such as cable conductor or interface falls off when open the cover.	
	Please make sure to cut the power off when you open the cover to carry on any operation.

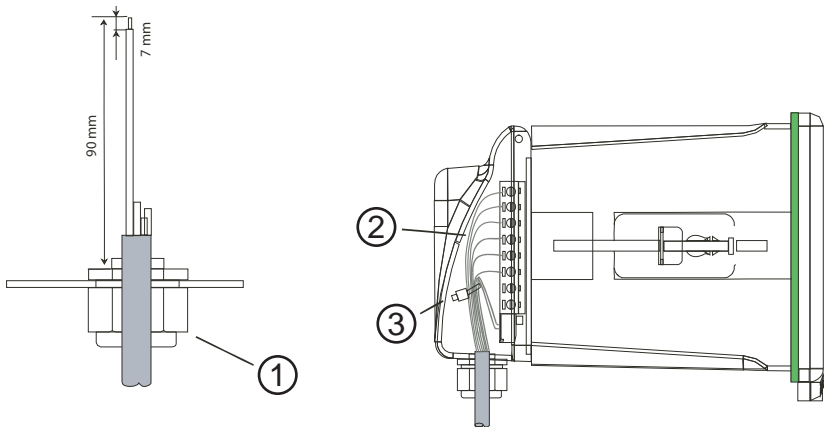

1. Waterproof cable glands
2. Cable (Recommended stripping length for cables is at least 90mm, please use 0.5 to 1 square meter's wire)
3. Cable ties

2 PRODUCT DESCRIPTION

2.1 DESCRIPTION OF INSTRUMENT SPECIALITY

CLEAN pH / ORP 5000,5500 Controller/Transmitter are used to measure pH or ORP and temperature value.

The transmitters can be panel-mounted or wall-mounted. They can be used as monitor in water treatment, controller in electrolytic water cleaning, in chemical industry, in food process, in cleaning water or waste water treatment and in neutralization process.

This transmitter has many user-friendly and safety features which include:

- Menu-driven program that simplifies set-up.
- High protection against electromagnetic interference.
- IP65 rated, waterproof and anti-gas, applicable in any extreme conditions.
- Built-in memory backup to ensure that setup parameter and calibration information are not erased in power-off condition.
- Independent setting for process temperature (TST1) and calibration temperature (TST2) in manual temperature compensation (MTC) mode. Under automatic temperature compensation mode, instrument will automatically switch to process temperature (TST1) in manual temperature compensation to ensure that the instrument can working normally. Please refer to Item 5.1.
- PH value can have the offset adjustment (± 2 pH) so that users can calibrate online. Please refer to Item 5.2.
- Scaleable isolated 0/4-20mA Outputs for pH/ORP. Please refer to Item 5.3.
- Two relay circuits, users can select high-low control freely.
- Separately adjustable high and low set-point hysteresis (dead bands) prevent chattering of relays around the set points.
- Two control modes: on/off limited control (LIT), proportion pulse length control (PLC). Two modes of relays can switch high-low point control freely. Please refer to Item 5.4.
- Two types of electrode input, symmetrical (under the strong interference industrial situation). Or asymmetrical input. Please refer to Page 17.
- Large dual display LCD for easy reading with clear multiple annunciators, alarm status and operational message annunciators. Long-life micro-switch key ease the setting.
- Can set the calibration time of instrument and electrode to reduce human management. Instrument will automatically appear "CAL" at regular time reminding calibration and maintenance. Please refer to Item 5.7.
- Automatically clean relay design. Users themselves can set cleaning time and install cleaning equipment. Please refer to Item 5.7.
- Glass electrode and antimony electrode are selectable and used under different industrial situations and HF measurement situation. Please refer to Item 5.8.
- During calibrating and setting, hold function freezes output current (0/4 - 20mA) and releases control relays.
- LED indicators signal control activities can monitor controller status from a distance.
- Large LCD, with high luminance LED orange backlight.
- RS-485 output can set tandem transmitting rate and ID NO. by itself. Maximum 128 instruments can be connected with computer to provide convenient management for terminating machine.

2.2 MEASUREMENT AND CONTROL SYSTEM

Typical measurement system includes:

- pH/ORP on-line transmitter.
- pH/ORP combination sensor with Pt1000 temperature probe or 3-in-1 sensor.
- Suitable pH/ORP measurement cable.
- Immersion system or flow tank or processing parts with or without grounding electrode.
- Terminating controlling parts, eg. Pump or valve.
- 0/4~20mA can connect with recorder.
- RS-485 can be used as multi-instrument communication.
- RL3 relay can be used as multi control or as alarm.

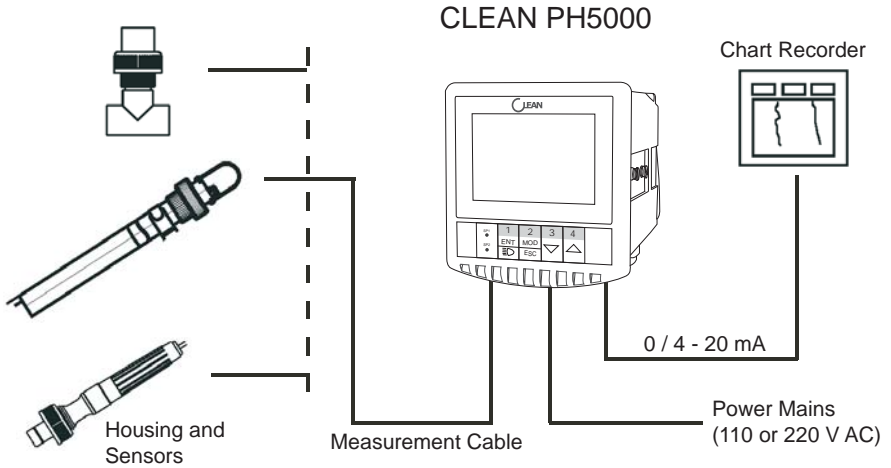

2.3 APPEARANCE

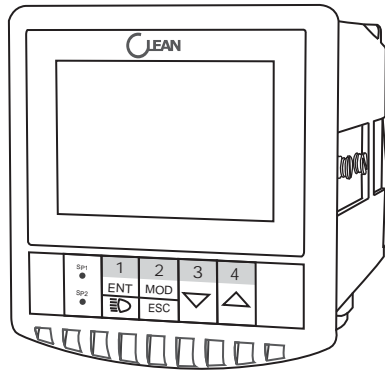

PH5000 pH and ORP Controller / Transmitter

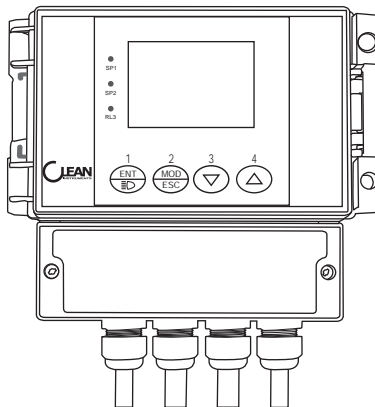

PH5000 pH and ORP Controller / Transmitter

2.3.1 DISPLAY INTRODUCTION

Two line LCD indicate measured value and various indications and parameters under different conditions.

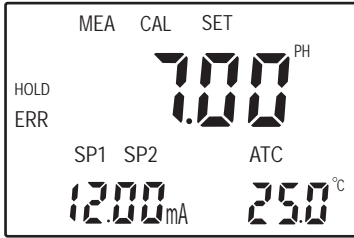





Mode:

- **MEA**: Measurement mode
- **SET**: Set-up mode
- **CAL**: Calibration mode

Status:

- **HOLD**: Freeze relay actions and current output.
- **ATC**: Automatic Temperature Compensation.
- **ERR**: Error or Warning Indication.

2.3.2 KEY INSTRUCTION

KEY	Description
	<ul style="list-style-type: none"> • Mode switch or Exit from current mode of operation
	<ul style="list-style-type: none"> • Confirm selection • Enter into function group in setting up mode • Confirm setted parameter and value • Start calibration in calibration mode • Back light switch in measurement mode
 	<ul style="list-style-type: none"> • Select function group in setting up mode to set parameter and value (Hold the key, value changing will be quicker.)

2.3.3 LED Induction

Relay Introduction

SP1\SP2 LED indicates relay's working status.

SP1\SP2 LED light luminating indicates that relays are under working status.

2.3.4 Password

When entering calibration mode and setting mode, there are passwords. Passwords are set by manufacturers and users can not modify them. Passwords are listed below :

Password	Mode / Instruction
028	Calibration Mode
058	Set-up Mode

2.3.5 FUNCTION PREVIEW

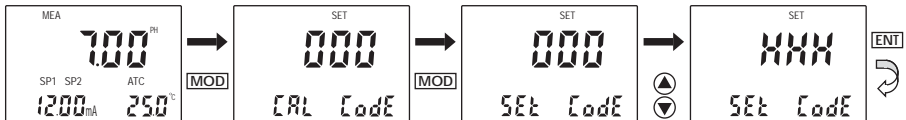

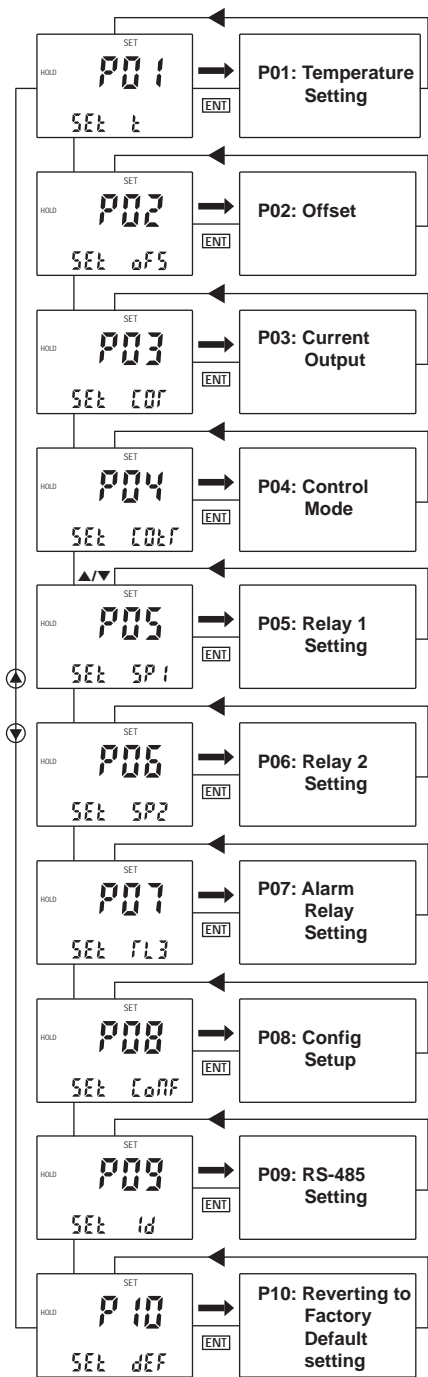

3 INSTALLATION AND ACCESSORY

INSTALLATION

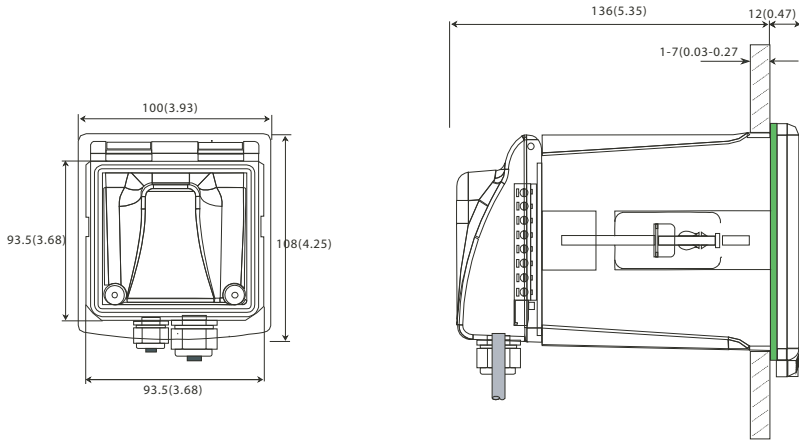

Panel cutout : 93.5*93.5mm (± 0.5 mm)
(panel-mounting)

Wall-mounting

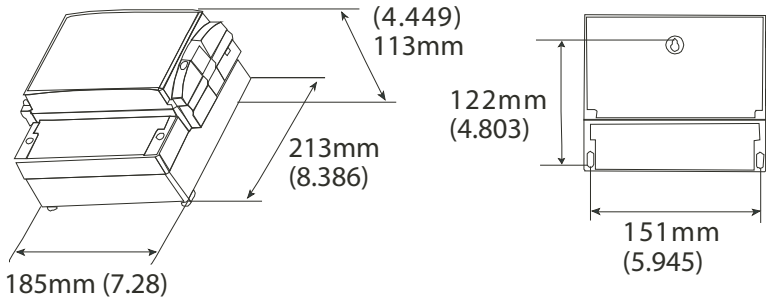

PH5000 CONNECTION DIAGRAM



Warning: Make sure to power off the meter before connecting. The rear panel consists of three connectors.

PH5000 Connection Diagram

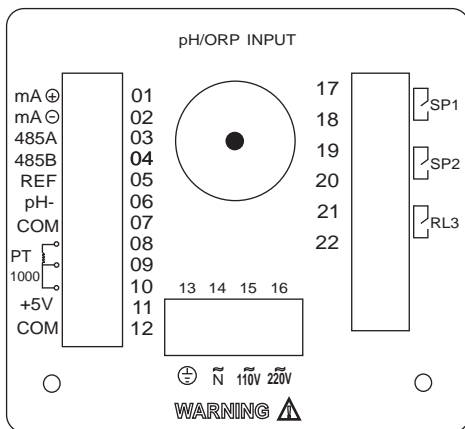

NEW VERSION	
1. pH value 4—20mA output, positive terminal	14. AC Earth wire
2. pH value 4—20mA output, negative terminal	15. Power input 110V AC (220 / AC Prohibited)
3. 485A output	16. Power input 220V AC (110 / AC Prohibited)
4. 485B output	17. Relay A (SP1)
5. Y Connector Reference Electrode	18. Relay A (SP1)
6. Short circuit with 7 in normal condition	19. Relay B (SP2)
7. COM, connect to the earth wire in strong interference	20. Relay B (SP2)
8. Temperature electrode positive terminal (PT1000)	21. Clearing Relay (RL3)
9. Temperature electrode negative terminal (PT1000)	22. Clearing Relay (RL3)
10. Temperature electrode sensing terminal (2-wire system, use short circuit between 8 and 9)	pH/ORP input terminal
11. +5V	
12. COM	
13. Earth wire	

NOTE: Short circuit between 6 and 7 pin in normal condition. In strong interference condition, short circuit will be between 7 and earth (platinum grounding pin are strongly recommended to avoid interference)

PH5500 CONNECTION DIAGRAM



Warning: Make sure to power off the meter before connecting. The front panel consists of three connectors.

PH5500 connection diagram

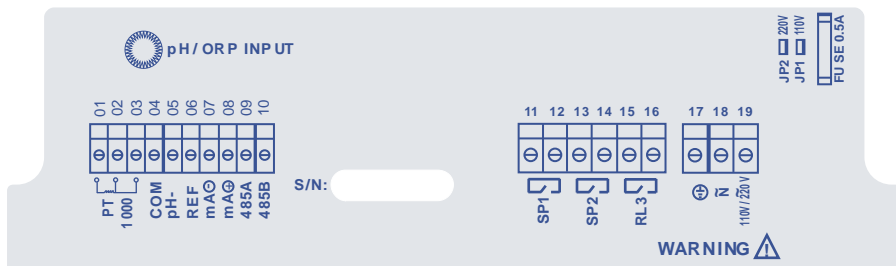

NEW VERSION	
1. Temperature probe positive terminal (PT1000)	12. Relay A (SP1)
2. Temperature probe negative terminal (PT1000)	13. Relay B (SP2)
3. Temperature probe sensing terminal (If using two-wire system, please make short circuit between 2 and 3).	14. Relay B (SP2)
4. COM (short circuit with 5 in normal condition)	15. Clearing Relay
5. pH negative terminal	16. Clearing Relay
6. REF	17. Earth wire
7. pH value 4—20mA Output, negative terminal	18. AC Earth wire
8. pH value 4—20mA Output, positive terminal	19. Power input 110V AC / 220V AC
9. 485A output	Jodhpurs JP2 220V
10. 485B output	Jodhpurs JP1 110V
11. Relay A (SP1)	 pH/ORP input terminal

MEASUREMENT MODE

When the controller is powered on, first the large dual LCD displays all icons briefly, then the controller will automatically enter into the measurement mode.



Notice: In order to get precise measurement value, users should calibrate the measurement system (Transmitter and Electrode).

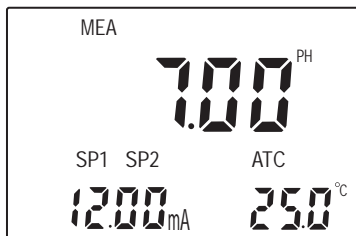

MEA on top of the LCD indicates that the instrument is under the measurement mode. The upper display indicates pH or ORP value, while the lower display indicates temperature value under pH measurement mode or ORP under ORP measurement mode. Icon at the left lower side of the display area indicates the value of output current, which help the users to check the value.

pH, mV, %, at the right upper side of the display indicate the current measurement mode.



In measurement mode, you can press  key once or twice to enter into the function form of calibration or setting password. Then input relevant password to enter into calibration mode or set-up mode. Please refer to Item 3 (Calibration Mode) or Item 4 (set up mode).



Press  key in measurement mode to open or close LCD backlight function.

4 CALIBRATION MODE



You can press **MOD/ESC** once in measurement mode and then input password 028 to get access to calibration mode. Please operate according to following procedures.

4.1 ENTERING CALIBRATION MODE

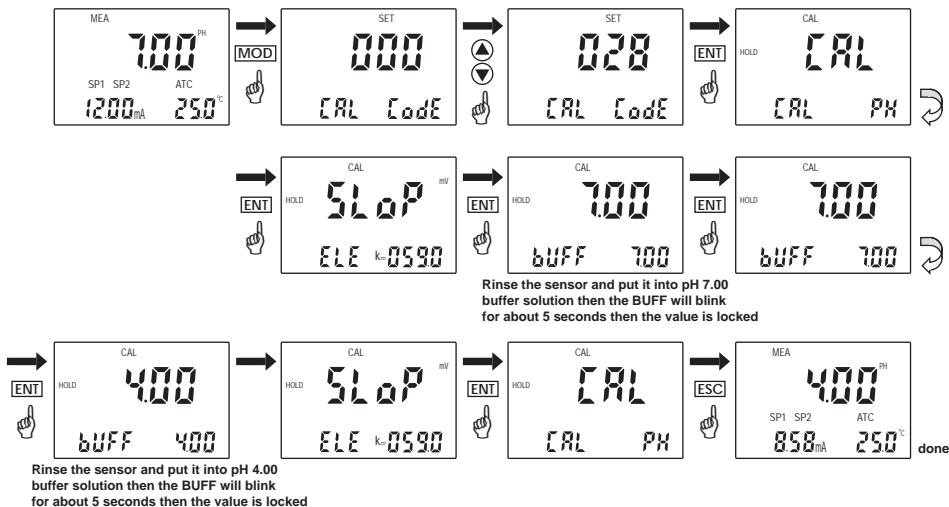

1. Press **MOD/ESC** once in measurement mode and enter into calibration password input menu.

2. After entering calibration password input menu, LCD will remind you to input the password. Press **▲/▼** to input calibration password 028, then press ENTER to confirm.

3. Press ENTER to enter into calibration menu, if the instrument is in pH measurement mode, lower display will show CAL pH. If the instrument is in ORP measurement mode, lower display will show CAL ORP. For more information, please refer to relevant items. (Please refer to upper procedures).



NOTE: Anytime, press **MOD/ESC** to exit from calibration mode and return to former function. If pressing twice, it will return to measurement mode, old calibration data will be kept and used. After returning to measurement mode, password will automatically switch from 028 to 000 when entering calibration mode.

4.2 pH CALIBRATION

This instrument can have one point or two point calibration in pre-set standard buffer solutions. The value of standard buffer solutions is based on 25°C. You should use the standard buffer solutions when you calibrate the instrument.

1. Enter calibration mode as in Item 4.1. LCD will show CAL pH. (pH Calibration mode).

Note: If LCD shows **CAL ORP**, please switch pH and ORP measurement mode according to the procedures of Item 5.8.



2. Press  to enter into calibration, LCD will show slope menu. The lower display will show ELE K=59.1. The menu will indicate the slope of last calibration. The upper display will show

CAL and the main display area will show SLOPE. Press  to enter into calibration procedures, LCD main display area will show measured value, the right lower display will show the value of standard solution which should be calibrated.

3. Put electrode into the first standard buffer solution. You should also put temperature probe into the solution under the automatic temperature compensation mode. You should put liquid earth wire electrode into the solution in symmetrical input mode.



4. You can select one point calibration or two point calibration: Press  to calibrate pH at 6.86 or 7.00. The lower display shows BUFF 6.86 (7.00) to tell user the standard buffer solution value. BUFF will blink when calibrating. In calibrating process, instrument will automatically tell electrode signals. If the signal input in required time is stable and in the slope permit range, the instrument will regard the calibration as accurate calibration, it will record and modify the zero point calibration data of the electrode. The lower display will show BUFF 1.68 to tell the standard solution value of the second point of calibration. Users can press ▲ or ▼ key to select relevant calibration solution. (USA 1.68>4.01>10.01>12.45) (NST 1.68>4.01>9.18>12.45).



Press  twice to exit from one-point calibration and return to measuring mode.



Press  next point calibration.









Take electrode out of the first standard solution, rinse it and put it into the second standard buffer solution.

5. If selecting one point calibration, instrument will indicate the slope, but zero point adopts new calibration value while the slope remains the value of last calibration. If selecting two point calibration, the lower display will show the next value of standard buffer solution value. Use ▲ or ▼ key to select the second standard buffer solution from the pre-set standard buffer solution. Take electrode out of the first standard solution, rinse it and put it into the second standard solution.



Press  key, BUFF will blink. Instrument will modify the value to the value of standard buffer solution.



6. After finishing the second calibration, instrument will automatically show SLOP on LCD main display zone. The right lower display shows the slope of electrode. Value of zero point and slope will be renewed after each calibration. After calibration, press MOD/ESC to return to the measurement mode.

	<p style="text-align: center;">  </p> <p>NOTE: Press  key twice to exit from setting up mode at any time. Instrument will return to measurement mode automatically.</p>
	<p>NOTE: Transmitter will show ERR when calibration is wrong. In this case,</p> <p style="text-align: center;">  </p> <p>press  to exit and calibrate again from step 1. It will show ERR again under following situations:</p> <ol style="list-style-type: none"> (1) Use wrong buffer solutions or buffer solutions have expired. (2) Electrode is aging or not clean or bubble is broken. (3) Electrode wire is broken or electric leakage because of joint corrosion.
	<p>NOTE: When calibrating under manual temperature compensation, transmitter will automatically switch from pre-set measurement temperature to calibration temperature. When exiting from calibration mode, transmitter will switch to measurement temperature again. (Please refer to Item 5.2 for setting measurement temperature and calibration temperature)</p>
	<p>NOTE: ELE K=59.1 indicates the electrodes conversion coefficient is 59.1mV/pH which means each pH is converted by 59.1mV potential at 25°C.</p> <p>For example: when slope is 90%, the conversion coefficient is $59.1 * 90\% = 53.19$.</p> <p>When the conversion coefficient is lower than 45mV, which means the slope is 75%, users should change electrode. Instrument will show ERR automatically when the conversion coefficient is lower than 40mV, which means the slope is 67%.</p>

4.3 ORP-mV CALIBRATION

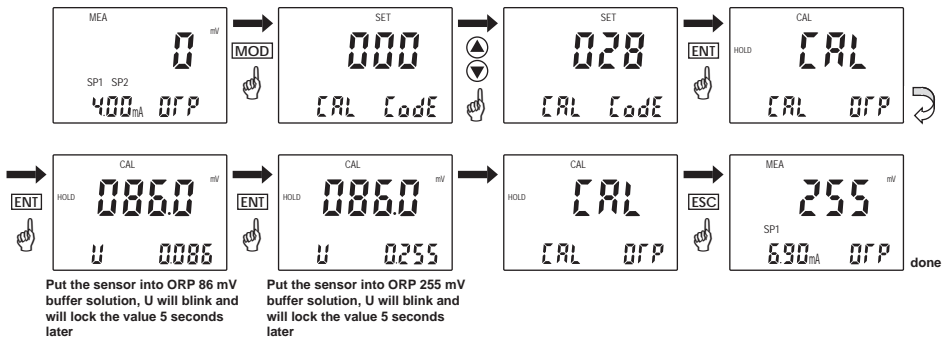
In ORP measurement mode, you can just have one point calibration.



1. Enter calibration mode as described in Item 4.1. LCD will show CAL ORP.
Note: If LCD shows CAL pH. Please switch to ORP mode from pH mode according to Item 5.8.
2. Put ORP electrode into ORP standard buffer solutions (86mV).
3. Press  to begin calibration. The mV value displayed is the mV value outputted by ORP electrode without offset. The lower display will show U and blink. If one point calibration is finished, instrument will automatically modify the value to 86mV. Then, the lower display shows 255mV to tell user to change buffer solution.
4. Rinse the electrode and put it into the buffer solution. Press  to confirm. Controller will enter into calibration status. After calibration, controller will automatically return to slope display menu. Press  twice to return to measurement mode and finish calibration process.

5 SET UP MODE

ENTERING SET UP MODE



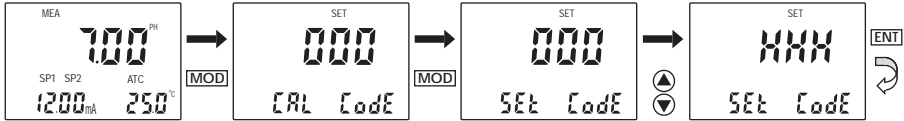

In setting up mode, transmitter can be set up according to your need.



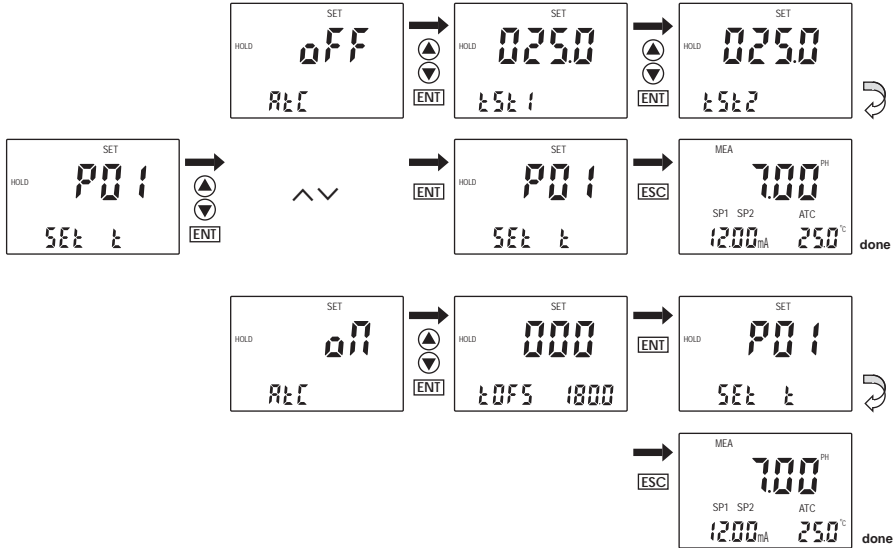

	1. Press MOD twice in measurement mode, the lower display area will show SET CODE.
	2. LCD will remind you to input password. Use ▲ or ▼ to input the password. – Input 058 to change parameter. (Please refer to Connection Instruction)
	3. Press ENT to confirm.
	NOTE: Press MOD twice to exit from setting up mode at anytime. Controller will return to measurement mode automatically.

5.1 P01: TEMPERATURE SET-UP FUNCTION



- In P01 screen, press  to enter. LCD main display area will show ON, which indicates automatic temperature compensation function is open. User can press ▲ or ▼ to switch to OFF and close automatic temperature compensation function.
- Press  when automatic temperature compensation function is open, instrument will enter into modification status of temperature measurement value. LCD main display area will show current measurement value of temperature. The lower display area will show TOFS to show that users can use ▲ or ▼ to modify current temperature display value. Press  to confirm and return to P01 function. Use ▲ or ▼ to select other functions or press  twice to return to measurement mode.





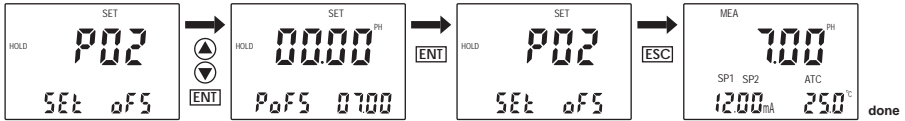

3. In the status of manual temperature compensation, press  and controller will enter setting up mode. User can use ▲ or ▼ to set up process temperature TST1 and calibration temperature TST2.

Press  to confirm and return to P01 function or press ▲ or ▼ to select other functions to setup

or press  to return to measurement status. TST1 is the compensation temperature under normal measurement while TST2 is the compensation temperature under calibration. Since temperatures are not the same in calibration and normal measurement when instrument is used, two set up values under manual temperature compensation status are convenient. Users will not set manual temperature compensation value back and forth. For example, if user's process temperature is 50.0°C and the temperature of standard solution when calibrating is 10.0°C, user can set TST1 as 50.0°C and set TST2 as 10.0°C for convenient use afterwards .









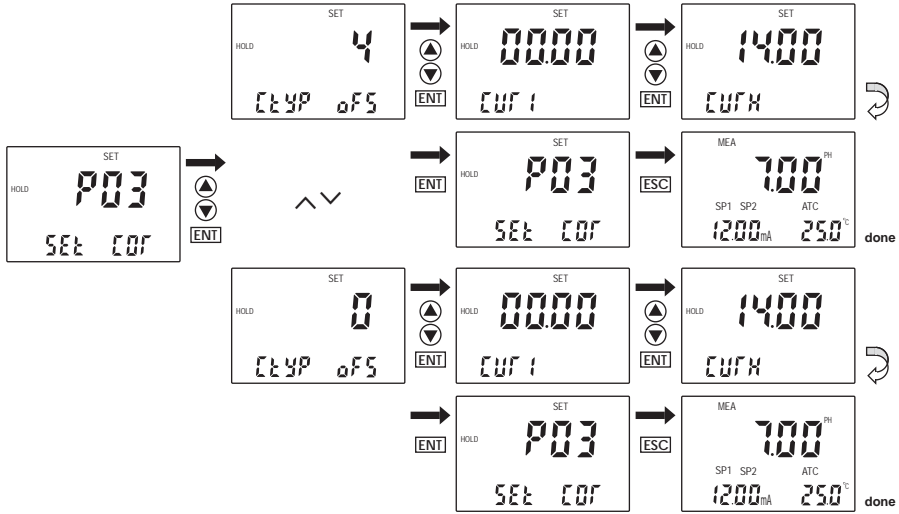

5.2 P02: OFFSET SET-UP FUNCTION



	<p>1. In P02 screen, Press . LCD main display area shows pH measured value in pH measurement mode. The lower display shows POFS. The right lower display shows offset.</p> <p>LCD main display area shows ORP measured value in ORP measurement mode. The lower display shows UOFS. The right lower display shows offset.</p>
	<p>2. User can press ▲ or ▼ to adjust offset to modify measurement value. Press  to confirm and return to P02 function . Use ▲ or ▼ to select other function to set up.</p>
	<p style="text-align: center;">  NOTE: Press  twice to exit from setting up mode at anytime. Controller will return to measurement mode automatically. </p>





5.3 P03: OUTPUT CURRENT (SP1/SP2) FUNCTION

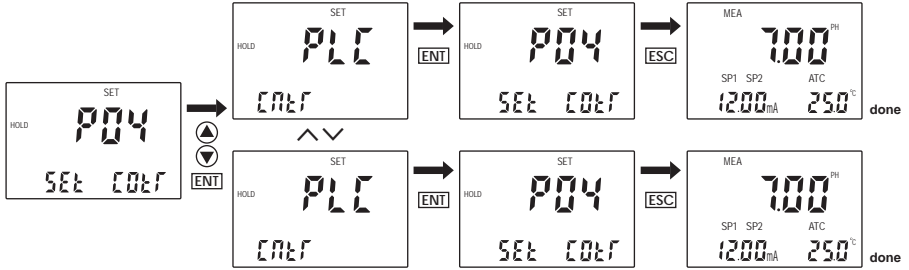

	<p>1. Press  to confirm in P03 function. Entering set up mode.</p>
	<p>2. The lower display shows CTYP. The upper display shows 4 (it means current output is from 4 mA to 20 mA). User can press ▲ or ▼ select 0 (it means current output is from 0 to 20 mA). Press  to confirm and enter into set-up of transmitting range.</p>
	<p>3. The lower display shows CURL while the upper display shows 0.00, which indicates that 0.00mA transmitting range is equal to 0.00pH. User can press ▲ or ▼ to adjust the actual value. Press  to confirm. The lower display shows CURH while the upper display shows 14.00, which means 20.00mA transmitting range is equal to 14.00pH. User can press ▲ or ▼ key to adjust the actual value. Press  to confirm and return to P03 screen. Use ▲ or ▼ to select other functions to set up.</p>
<p>For example, set CTYP to 0 or 4, set CURL to 2.00 and set CURH to 10.00, which means 0/4 to 20mA output mode is selected as current output. 0/4.00mA indicates 2.00pH, 20.00mA indicates 10.00pH.</p>	
	<p>NOTE: Press  twice to exit from setting up mode at anytime. Controller will return to measurement mode automatically.</p>
	<p>NOTE: This parameter allows you to set range of current output, but transmitting high point and low point can't overlap.</p>







5.4 P04: CONTROL MODE FUNCTION

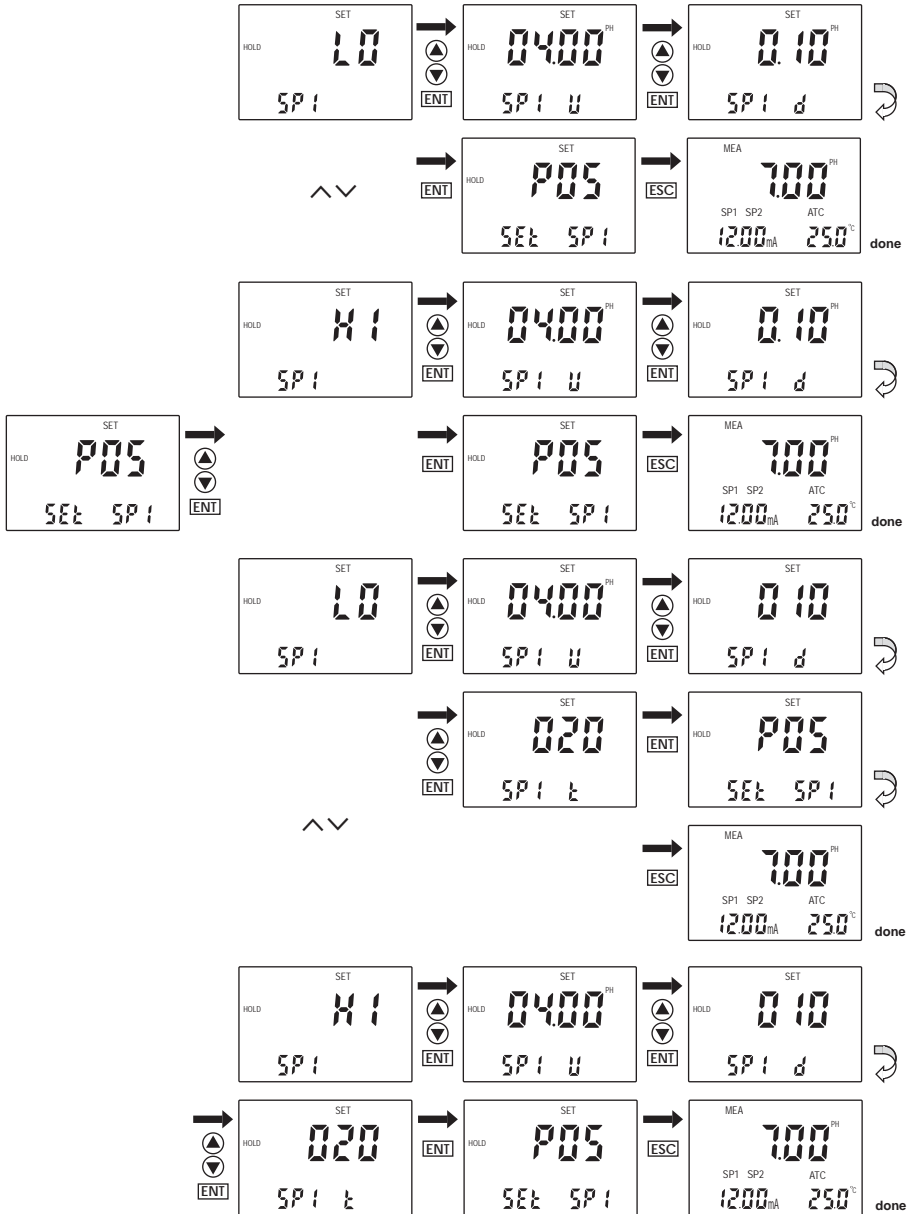

- | | |
|---|--|
|  | <p>1. Press  in P04 screen to enter into the setting up procedure.</p> |
| | <p>2. The lower display shows CNTR while the upper display shows LIT. (The control mode of controller is under limited control mode). User can press ▲ or ▼ to select PLC mode (The control mode of instrument is under proportion control mode). Press  to confirm and return to P03 function. Use ▲ or ▼ to select other functions and to set up.</p> |
| | <p>NOTE: Press  twice to exit from setting up mode at any time. Instrument will return to measurement mode automatically.</p> |

5.5 P05: RELAY 1 SET-UP FUNCTION



	<p>1. In P05 menu. Press  to enter into setting-up procedure.</p>
	<p>2. The lower display shows SP1 while the upper display shows HI, which indicates set point 1 is under high-point control status. (If instrument control is set up to LIT limited point control mode, relay begins to work when the measured value is up to the set value. If instrument control mode is set up to PLC control mode, the measured value must be raised to approach the set value). Press  to confirm and enter into next set up procedure.</p>
	<p>3. The lower display shows SP1 U while the upper display shows value. User can press ▲ or ▼ to adjust the value to confirm the set up value. Press  to confirm and enter into next set up procedure.</p>
	<p>4. This function sets hysteresis band under limited control mode to protect relay, which may oscillate frequently around set point and be damaged. Controlling proportion range is set up under proportion control mode (this parameter is not lower than 5 under PLC mode) to confirm and adjust time period of adding medicine automatically. Press  to confirm and enter into next set up procedure. Under proportion control mode, this function is used to set time period of whole controlling circle. Press  to confirm and return to P05 function menu. USE ▲ or ▼ select other function and to set up.</p>
	<p>NOTE: Press  twice to exit from setting up mode at any time. Controller will return to measurement mode automatically.</p>

5.6 P06: RELAY 2 SET-UP FUNCTION

Working principle of this part is the same as in P05 relay 1 set-up function. Please operate according to P05.

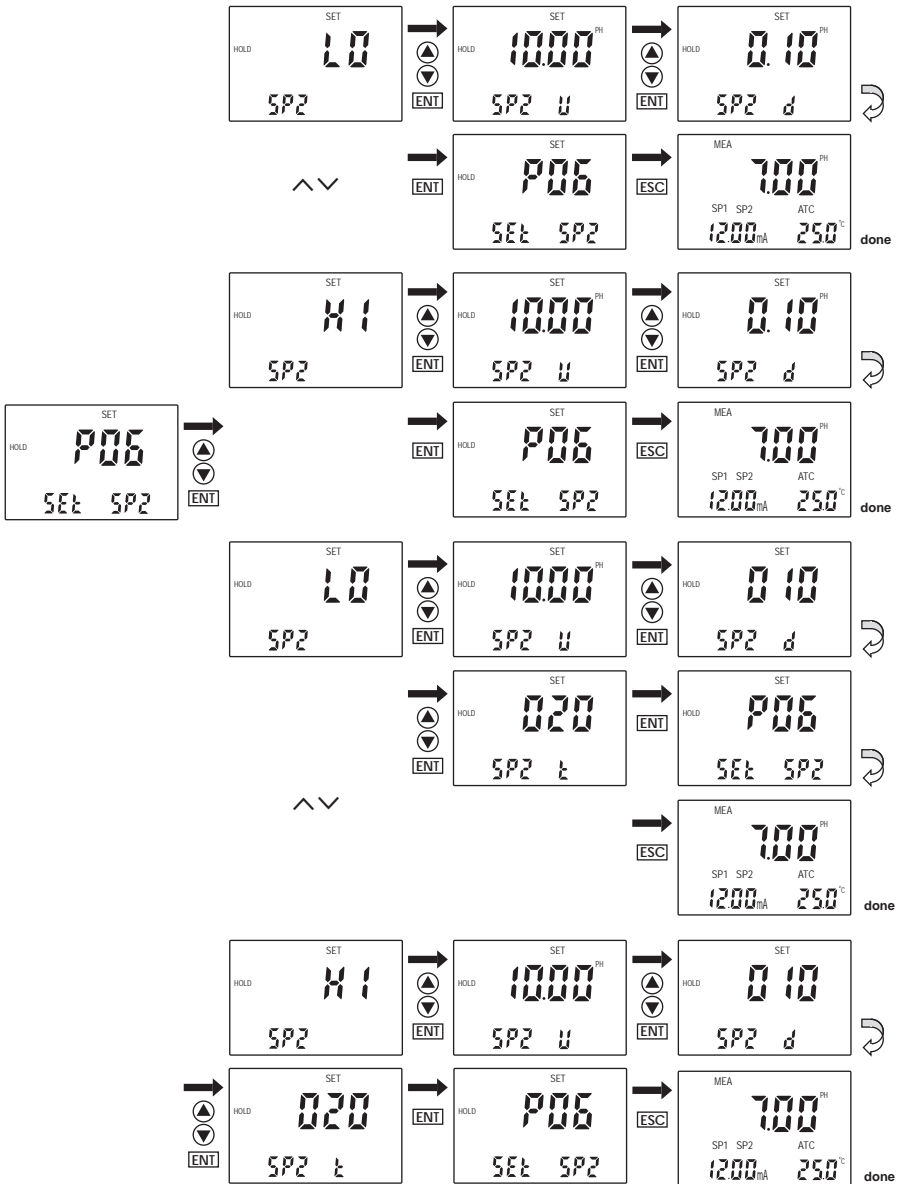

NOTE: Set-up value range of hysteresis band under limited control mode is from 0.00 - 2.0pH.

For example, if high point is 7.00pH and hysteresis band is 0.50pH, movement range of the relay is from 6.50pH to 7.00pH. If low point is 6.00pH and hysteresis band is 0.20pH, movement range of the relay is from 6.00pH to 6.20pH.

NOTE: In PLC control mode, movements of the relay meet following formulas:

$$C * (VM - VS) * U * T / 14$$

C is discriminant coefficient for high / low point.

It is -1 when set to high point and it is 1 when set to low point.

VM is measured value.

VS is set value.

U is control parameter.

T is time constant (represent relay's whole movement circle)

For example, set high point is 7.00pH, actual measured value is 6.50pH, control parameter is 10, time constant is 10 seconds.

$$-1 * (6.50 - 7.00) * 10 * 10 / 14 = 3.57 \text{ second}$$

According to the above formula, pickup time of relay is 3.6 second and release time is 6.4 seconds. If the result of above formula is negative, relay won't move. If the result is move than T, relay keeps picking up until the result is less than T.

5.7 P07: ALARM RELAY 3 SET-UP FUNCTION

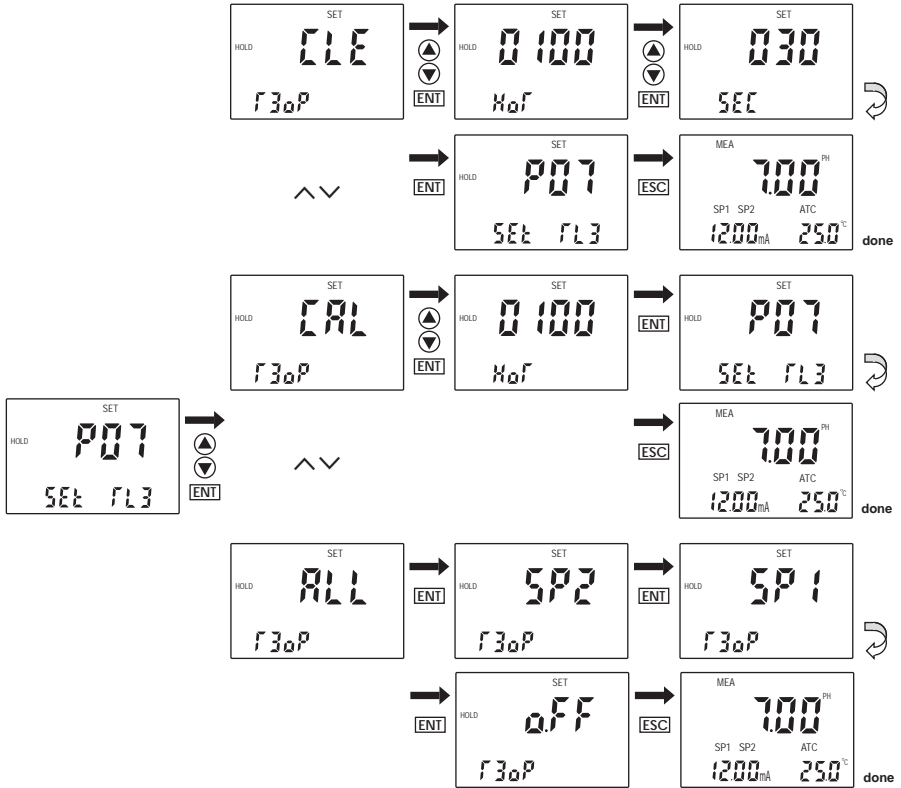

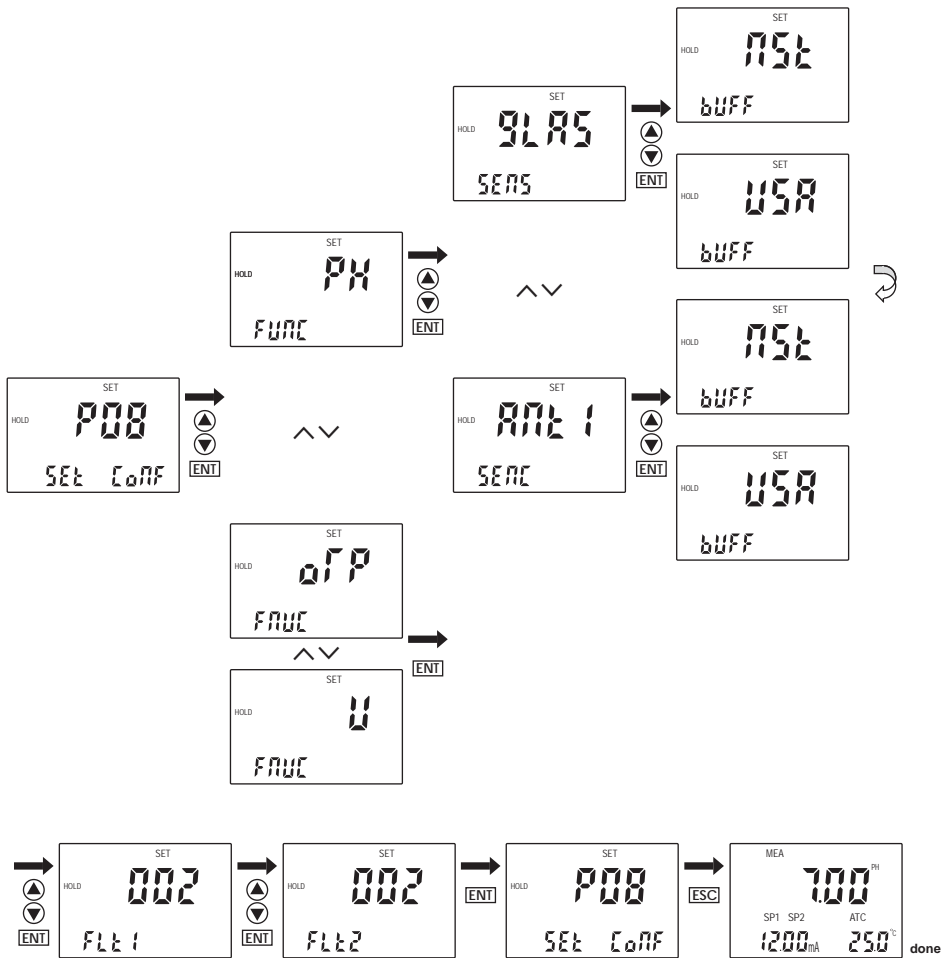

<p>1. Select P07 function, Press</p>	<div style="border: 1px solid black; padding: 2px; display: inline-block;">1 ENT</div>	<p>to confirm. Enter into set-up procedure.</p>			
<p>2. Select working mode. Press</p>	<div style="border: 1px solid black; padding: 2px; display: inline-block;">3 ▽</div>	<p>or</p> <div style="border: 1px solid black; padding: 2px; display: inline-block;">4 △</div>	<p>to select suitable control mode.</p> <ul style="list-style-type: none"> - CLE=relay 3 as cleaning control relay - CAL=relay 3 as calibrating indication relay - ALL=move with two relays simultaneously - SP1=relay 3 moves with SP1 (limited control mode only) - SP2=relay 3 moves with SP2 (limited control mode only) - OFF=relay 3 is off (factory default) <p>Press ENTER to confirm your set up.</p> <p>If selecting CAL working mode, user can set calibration intervals in the function menu, use “hour” as the unit. In this way, instrument and electrode can keep their reliability. If selecting CLE working mode, user can set cleaning time intervals in the function menu, use “hour” as the unit. As to the cleaning continuous time, use “second” as the unit. In this way, instrument and electrode can keep their reliability. User can install cleaning equipment to increase service life and reliability of electrode.</p>		
<p>3. Press</p>	<div style="border: 1px solid black; padding: 2px; display: inline-block;">1 ENT</div>	<p>to confirm and return to P07 function. Use</p>	<div style="border: 1px solid black; padding: 2px; display: inline-block;">3 ▽</div>	<p>or</p> <div style="border: 1px solid black; padding: 2px; display: inline-block;">4 △</div>	<p>to select other functions to set up.</p>
	<p>NOTE: Press <div style="border: 1px solid black; padding: 2px; display: inline-block;">2 MOD</div> <div style="border: 1px solid black; padding: 2px; display: inline-block;">ESC</div> twice to exit from setting up mode at any time. Controller will return to measurement mode automatically.</p>				

5.8 P08: pH/ORP ELECTRODE SELECTION, BUFFER SELECTION AND DIGIT FILTER FUNCTION





1. In P08, Press  to confirm and enter into setting up procedure.

2. Press  to confirm. If you select ORP or voltage measurement mode, press  to confirm, instrument will return to P08 function. If you select pH measurement mode, instrument will enter electrode-selecting function automatically. The lower display shows SENS, and main display area shows the type of electrode, glass or antimony electrode. User can use ▲ or ▼ to select the electrode.

Then, press  to confirm and enter into standard solution selection. The lower display shows BUFF while the upper display shows NST (Nist standard) or USA (USA standard). User can use ▲

or ▼ to select according to the type of standard solution, press  to confirm. Next is the

Temperature Filter (Filter 1), press ▲ or ▼ key to set the number, then press  to confirm, and then that will enter the pH/ORP Filter (Filter 2). Press the ▲ or ▼ key to set the number and press

the  to confirm. Press  to confirm and return to P08 function form. Use ▲ or ▼ select other functions to set up.



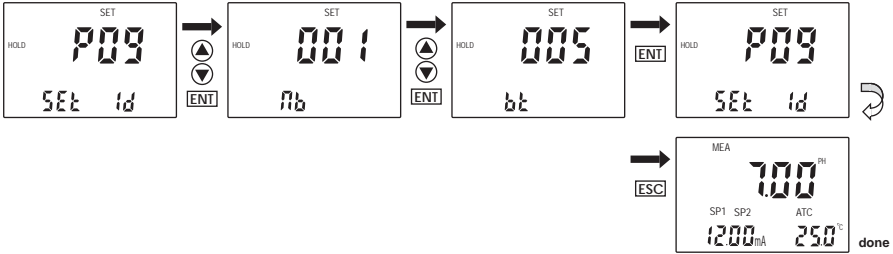

NOTE: Press  twice to exit from setting up mode at any time. Controller will return to measurement mode automatically.

5.9 P09: TRANSMITTING RATE FUNCTION





1. Press  to confirm in P09 and enter setting up procedures.

2. The lower display shows nb while the upper display shows 001, which indicates that user is setting communication address ID NO. of the instrument, from 001 to 128. Use ▲ or ▼ to select necessary ID and press  to confirm. Then enter into next set up function.

3. The lower display of the instrument shows bt while the upper display shows 005, which indicates that user is setting communication rate function. Use ▲ or ▼ to select necessary communication rate. Press  to confirm and return to P09 function form. Use ▲ or ▼ to select other function to set up.

4. Transmitting rate corresponding to codes.

bt	000	001	002	003	004	005	006	007
baud rate	300	600	1200	2400	4800	9600	19200	38400

 **NOTE:** Press   twice to exit from setting up mode at any time. Controller will return to measurement mode automatically.

5.10 P10: REVERTING TO FACTORY DEFAULT SETTINGS

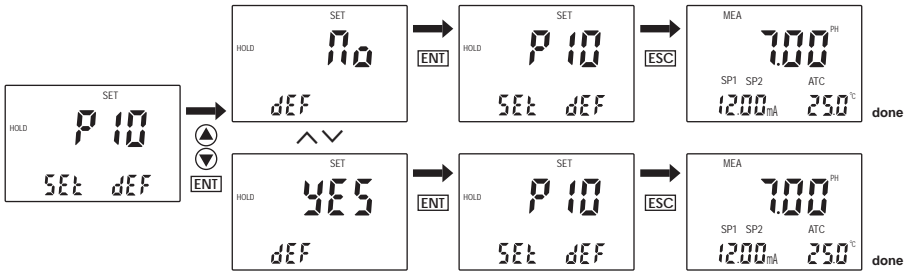

	<div style="border: 1px solid black; padding: 2px; display: inline-block;"> 2 MOD ESC </div>
<p>NOTE: Press 2 MOD ESC twice to exit from setting up mode at any time. Controller will return to measurement mode automatically.</p>	

1. Press 1
ENT in P10 to enter into setting up procedures.
2. The lower display of the instrument shows DEF while the upper display shows NO (YES). User can press ▲ or ▼ to select necessary items. If select YES, all settings will be reset to factory default. User's setting will be lost.

5.11 COMMUNICATION PROTOCOL

1. Protocol Setting

This instrument uses RS-485 communication. It's can be connected with 1 to 64 instruments in 2 wires at the same time and communicate with PC. The distance of communication is around 1200M.

The data form is "N81" (1 start bit, 8 data bits, 1 stop bit, NO verify check code).

The baud rate is 300 to 38400 bit/s (usually is 9600 bit/s).

Users have to set the ID (NB) of the instruments and the baud rate (BT) before connecting to RS-485.

Bt	0	1	2	3	4	5	6	7
speed	300	600	1200	2400	4800	9600	19200	38400

Usually, the instrument is stand by in receiving status. Once it receives the correct ID then it will send out the data to PC. Finished sending it will enter to receive status again.

To avoid the conflict, each instrument has to use different ID (decided by NB).

All of the instruments and PC must use the same baud rate (decided by BT).

2. Data form

All one-word data is from -32767 to +32767, using the hexadecimal number system, the high bit is sign.

All one-byte is integer.

The data is ASCII code :the start sign is @ (40H), the end sign is CR (0DH).

The other data use the ASCII code to express the hexadecimal number system.

All data should be between 30H to 39H and 41H to 46H. the instructions are form 41H to 5AH.

Double-byte sending: the low byte is the first, the high byte is the second.

One-byte sending: the high nibble is the first, the low nibble is the second.

A full communication form is :40 ,ID, the sequence of the instruction,CRC,0D.

The ID is the number of the instrument (NB).

CRC (Circulation Redundant Codes) Verification is the bitwise XOR assignment of ID code and the sequence of instruction.

3. The communication instructions

1) RD: read floating data.

2) RE: read the appointment data by start address and bytes (the large byte can not over 28 bytes).

3) RR: read all of data (8-word, 12-byte), totally 28 bytes.

4. Introduce the instructions (the ID is 1)

1) RD (read the floating data): PC send: 40,30,31,52,44,CRCH,CRCL,0D (8 bytes)

40: start byte

30 31: the ID of instrument (the hexadecimal: 0~3FH, ASCII: 30 30~33 46):

52 44: instrction of R, D

CRCH, CRCL: Verification Byte, 2~5 bitwise XOR assignment

CRCH, CRCL: bitwise XOR assignment starting from Byte 2 to the byte before CRCH.

0D: the end byte

the response by instrument is "40, 30, 31, 52, 44, 30, 30, V1LH, V1LL, V1HH, V1HL, 3X, V2LH, V2LL, V2HH, V2HL, 3X, 3X, 3X, 3X, 3X, CRCH, CRCL, 0D"

40: the start byte

30 31: the ID of instrument

52 44 30 30: the fixed data

V1LH, V1LL, V1HH, V1HL: pH/ORP/DO/Dd value

3X: the position of decimal (30-33, correspondent with 0-3 decimal)

IOLH, IOLL, IOHH, IOHL (output current value)

FATC (30: OFF; 31H: ON)

V2LH, V2LL, V2HH, V2HL: temperature value
 JD1: the status of relay 1, 30: open; 31: close
 JD2: the status of relay 2, 30: open; 31: close
 JD3: the status of relay 3, 30: open; 31: close
 FKER: KERR status, 30: correct; 31: error
 FCHG: parameter modify, 30: no modify; 31: modify
 CRCH, CRCL: bitwise XOR assignment starting from Byte 2 to the byte before CRCH.
 0D: the end byte
 Total: 27 bytes

2) RE (read the appointment data)

The PC send: 40, 30, 31, 52, 45, 30, 30, adrH, adrL, lthH, lthL, CRCH, CRCL, 0D (total 14 bytes)

40: the start byte

30 31: the ID of instrument (the hexadecimal: 0~3FH, ASCII: 30 30~33 46);

52 45: the instruction R, E;

30 30: reserve

adrH adrL: the address of the start parameter byte (the hexadecimal: 0~1BH; ASCII: 30 30~31 42);

1thH 1thL: the count of the parameters (the hexadecimal: 1~1CH; ASCII: 30 31~31 43);

CRCH, CRCL: Verification Byte, 2~11 bitwise XOR assignment.

0D: the end byte

The adr is the start address(00~1BH),1th is the count of the byte. The table is the relation of the adr and parameter.

adr	00	01	02	03	04	05	06	07	08	09	0A	0B	0C	0D
para	TST1	TST1	TST2	TST2	SP1U	SP1U	SP2U	SP2U	CURL	CURL	CURH	CURH	POFS	POFS
adr	0E	0F	10	11	12	13	14	15	16	17	18	19	1A	1B
para	HOR	HOR	AAA	FUNC	R3OP	TOFS	SEC	SP1D	SP1T	SP2D	SP2T	NB	BT	CONF

If $adr > 1BH$ or $adr + 1th > 1BH$, the return the error code: 40, 30, 31, 52, 45, 2A, 2A, CRCH, CRCL, 0D

The 2A 2A is the error sign

If the address range is correct then the instrument will send back data :

40, 30, 31, 52, 45, D1, D2, D3, Dn, CRCH, CRCL, 0D

40: the start byte

30 31: the ID

52 45: the fix data

D1~Dn: parameters from instrument to PC ($n=2 \times lth$)

CRCH, CRCL: bitwise XOR assignment starting from Byte 2 to the byte before CRCH.

0D: the end byte

Total Byte = $5 + 2 \times lth + 3$

3) RR (read all of parameters) the PC send: 40, 30, 31, 52, 52, CRCH, CRCL, 0D (8 bytes)

40: the start byte

30 31: the ID

52 52: the instruction of R, R

CRCH, CRCL: Verification Byte, 2~5 bitwise XOR assignment

0D: the end byte

The instrument response: 40, 30, 31, 52, 52, D1, D2, D55, D56, CRCH, CRCL, 0D (64 bytes)

40: the start byte

30 31: ID

52 52: the fix data

D1~D56: the parameter of sending (8 double byte, 12 byte, total 28 bytes)

CRCH, CRCL: Verification Byte, 2~5 bitwise XOR assignment

CRCH, CRCL: bitwise XOR assignment starting from Byte 2 to the byte before CRCH.

CRC

0D: the end byte

Total Byte = 5 + 2 × n + 3

5. Notice for programming the communication program:

- 1) If the instrument receives the data with the start byte is 40 and the count of sequence data over 16 bytes and did not find the 0D then the data is invalid. The instrument will not do any response.
- 2) If the sequence data is not between 00H to 0FH, the sequence data is invalid. The instrument will not do any response. But the other errors, ex: the wrong instruction, the wrong address, the wrong parameter counts, the wrong CRC and so on, the instrument will response the wrong information.
- 3) All parameters, please see the following table, some parameters include decimal.

para	TST1	TST2	SP1U	SP2U	CURL	CURH	POFS	HOR	KUSE	SP1D
decimal	1	1	1~3	1~3	1~3	1~3	1~3	0	3	1~3
para	SP2D	TOFS	SEC	R3OP	REFT	TCOE	CABR	RNGE	SP1T	SPTT
decimal	1~3	1	0	0	1	2	1	0	0	0

The PC display the reading values should be include the decimal.

- 4) TOFS is the correct value of temperature, the setting range is 0~200, the display range is -100~100, so the PC should be subtract 100 and display with sign.
- 5) FUNC is the display mode of instrument: 0=mV; 1=ORP; 2=pH; 0=CON; 1=TDS; 2=RES / 0=DO / 0=FCL.
- 6) R3OP is the mode of relay 3: 0=NOR; 1=SP1; 2=SP2; 3=ALL; 4=CAL; 5=CLE.
- 7) AAA is the reserve parameters.
- 8) CONF is a byte parameter, the define is following,
 - Bit 7: temperature compensation: 1=°F 0=°C
 - Bit 6: current output, 1=4~20mA; 0=0~20mA;
 - Bit 5: SP1, 1=HI; 0=LO;
 - Bit 4: SP2, 1=HI; 0=LO;
 - Bit 3: control mode, 1=PLC; 0=Lit;
 - Bit 2: electrode selection, 1=ANTI; 0=GLAS;
 - Bit 1: buffer, 1=NST; 0=USA;
 - Bit 0: reserve

6 TECHNICAL PARAMETERS

6.1 TECHNICAL PARAMETERS FORM

PH5000 / PH5500 Transmitter / Controller	
pH Range	- 2.00 to 16.00 pH
Resolution & Accuracy	0.01 pH and ± 0.01 pH
mV Range	- 2000 to 2000 mV
Resolution & Accuracy	1 mV / ± 1 mV
Temperature	- 9.9 to 130 °C
Resolution & Accuracy	0.1 & ± 0.5 °C
Temperature probe	Pt 1000
Temperature compensation	Automatic (± 10 °C offset adjustment) / manual
Set point and control function	
Control function	Limited point / proportion (pulse length)
Cleaning circle	From 1 to 999 hours
Cleaning time	From 1 to 999 seconds
Control hysteresis band	0.01 to 2 pH
ORP hysteresis band	1 to 200 mV
Relay output	3 SPST relays, 250V/1A
Communication	
RS-485	client program
Electric current information and connection	
Power	110 or 220 V AC
Signal output / load	0 / 4 - 20 mA isolated current output
Signal output load	600 Ω
pH / ORP input	BNC (10^{13} impedance)
Connection terminal	Removable plug-in unit
Main fuse wire	250 mA, anti-surge
Alarm function	
Function (switchable)	Alarm / Calibration Indication / Cleaning Control
Display	
LCD (liquid crystal display)	Large LCD, orange back light
EMC Specification	
Electromagnetic emission	EN 50081-1
Electromagnetic induction	EN 50082-1
Environmental conditions	
Working temperature	- 10 to 50 °C (14 to 122 °F)
Humidity	10 to 95% (no frozen dew)
Protection grade	NEMA 4X, IP 65

6.2 PARAMETER SETTING AND FACTORY DEFAULT SETTING

NO	Indication	Parameter	Symbol	Description	Remarks	Valid range	Default settings
01		LOCK	LOC	Entering password setting		0~200	0
02	P1 TC	ATC	AtC	Automatic temperature compensation		ON/OFF	OFF
03		TSET1	tSt1	Manual temperature setting	Only valid for manual	-10.0~100.0℃	25.0
04		TSET2	tSt2	Calibration temperature setting		0.0~60.0℃	25.0
05		TOFS	tOFS	Temperature measurement offset	Only valid for manual	-10.0~10.0℃	0.0
06	P2 OFS	POFS	POFS	pH value measurement offset	Only valid for PH mode	-2.00~2.00PH	0.00
		VOFS	VOFS	mV value measurement offset	Only valid for ORP mode	-200~200mV	0
07	P3 CUr	CTYP	CtyP	Type of current output		0/4~20mA	4
08		CURL	CUrL	Lower limit of transmitting output	PH mode: 0.01PH unit ORP mode: 1mV unit	-1999~1999	0
09		CURH	CUrH	Upper limit of transmitting output		-1999~1999	1400
10	P4Cntr	CNTR	Cntr	Relay 1, 2 Control		PLC/ Lit	Lit
11	P5 SP1	SP1	SP1	Relay 1 Setting		HI / LO	LO
12		SP1U	SP1U	Setting value of relay 1	PH mode: 0.01PH unit ORP mode: 1mV unit	-1999~1999	400
13		SP1D	SP1d	Relay 1 hysteresis / proportion		0~200(2.00)	10
14		SP1T	SP1t	Relay 1 circle (second)	Only valid for PLC	0~200 seconds	20
15	P6 SP2	SP2	SP2	Relay 2 Setting		HI / LO	HI
16		SP2U	SP2U	Setting value of relay 2	PH mode: 0.01PH unit ORP mode: 1mV unit	-1999~1999	1000
17		SP2D	SP2d	Relay 2 hysteresis / proportion		0~200(2.00)	10
18		SP2T	SP2t	Relay 2 circle (second)	Only valid for PLC	0~200 seconds	20
19	P7 rL3	R3OP	r3OP	Working mode of relay 3		OFF/SP1/SP2/ ALL/CAL/CLE	OFF
20		INT	HOOr	Interval (hour)	valid for calibration and cleaning mode	0~999	100
21		DUR	SEC	Operating time (second)	valid for cleaning mode	0~200	30
22	P8 CONF	FUNC	FUnC	PH / ORP / mV selection		PH/ORP/mV	PH
23		SENS	SenS	Antimony / glass electrode selection	Only valid for PH mode	Anti/GLAS	GLAS
24		BUFF	buFF	USA/nST standard selection		NST/USA	USA
26	P9 ID	NB	nb	Set ID number for 485		0~63	1
27		BT	bt	Communication rate		0~7	5
28	P10 DEF	DEF	dEF	Reverting to factory default setting	Reverting to factory default parameter.	YES/NO	NO

7 GENERAL INFORMATION

WARRANTY

CLEAN Instruments warrants this product to be free from significant deviations in material and workmanship for a period of one year from the date of purchase. If repair is necessary and has not been the result of abuse or misuse within the warranty period, please return to CLEAN Instruments and amendment will be made without any charge. CLEAN Instruments Customer Service Center will determine if product problem is due to deviations or customer abuse. Out of warranty products will be repaired on a charge basis.

RETURNING THE ITEMS

Authorization must be obtained from CLEAN Instruments Customer Service Center to issue a RIR number before returning items for any reason. When applying for authorization, please include date requiring the reason of return. Instruments must be carefully packed to prevent damage in shipment and insured against possible damage or loss. CLEAN Instruments will not be responsible for any damage resulting from careless or insufficient packing.

Warning: Damage as a result of inadequate packaging is the User / distributor's responsibility. Please follow the guidelines below before transporting.

GUIDELINES FOR RETURNING THE ITEMS

Use the original packaging material if possible, when transporting back the unit for repair. Otherwise wrap it with bubble pack and use a corrugated box for better protection. Include a brief description of any faults suspected for the convenience of Customer Service Center, if possible. If there are any questions, feel free to contact our Customer Service Center or distributors.

APPENDIX 2 - pH TEMPERATURE CORRESPONDING TO pH BUFFER SOLUTION

Following form shows standard PH value of standard buffer solutions under different temperatures.

Temperature (°C)	pH 1.00	pH 4.01	pH 6.86	pH 7.00	pH 9.00	pH 9.18	pH 10.01
0	0.96	4.01	6.98	7.12	9.33	9.47	10.32
5	0.99	4.01	6.95	7.09	9.24	9.38	10.25
10	0.99	4.00	6.92	7.06	9.16	9.32	10.18
15	0.99	4.00	6.90	7.04	9.11	9.27	10.12
20	1.00	4.00	6.88	7.02	9.05	9.22	10.06
25	1.01	4.01	6.86	7.00	9.00	9.18	10.01
30	1.01	4.01	6.85	6.99	8.95	9.14	9.97
35	1.01	4.02	6.84	6.98	8.91	9.10	9.93
40	1.01	4.03	6.84	6.97	8.88	9.07	9.89
45	1.01	4.04	6.83	6.97	8.85	9.04	9.86
50	1.01	4.06	6.83	6.97	8.82	9.01	9.83
55	1.01	4.08	6.83	6.97	8.79	8.99	9.81
60	1.02	4.10	6.84	6.98	8.76	8.96	9.79
70	1.02	4.12	6.85	6.99	8.72	8.92	9.76
80	1.02	4.16	6.86	7.00	8.68	8.89	9.74
90	1.02	4.20	6.88	7.02	8.65	8.85	9.73

APPENDIX 3 – HYSTERESIS BAND

Brief Introduction on the Function of Hysteresis Band

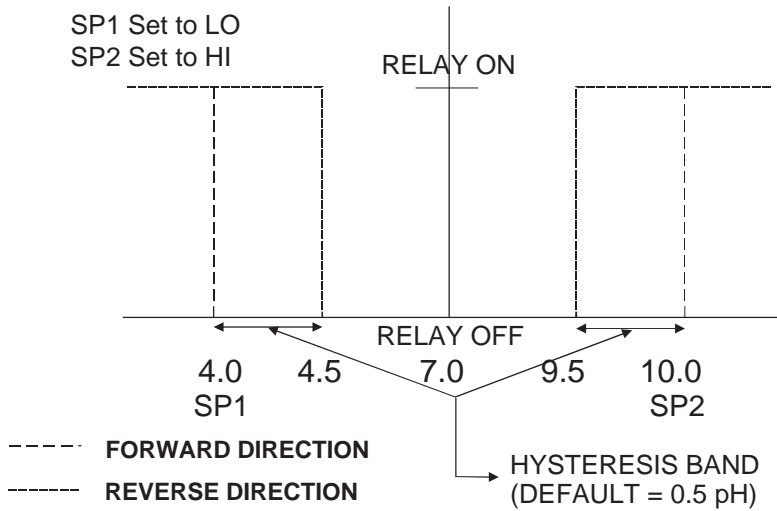

The controller relay activates when the set-point is reached. In the reverse direction, it closes. Relay continues to be active till the value reaches the amount set by hysteresis band.

APPENDIX 4 – CONTROL MOVEMENT

Brief Introduction On Controller Setting

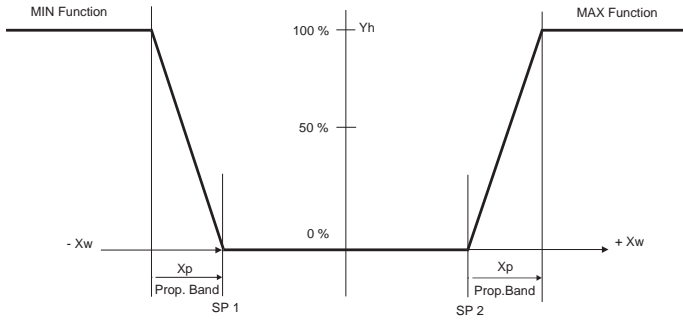

Control characteristic of P-Controller as proportional controller

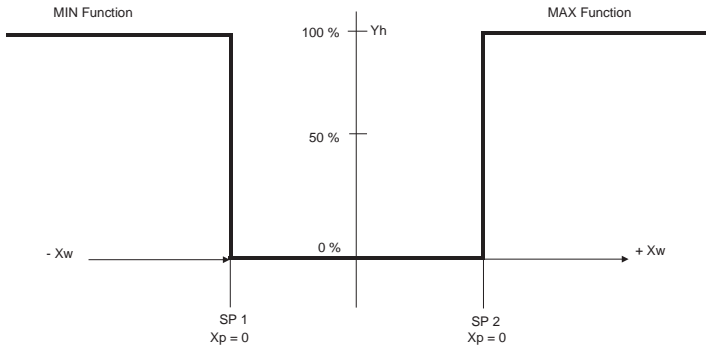

Control characteristic of P-Controllers as limit value switch Control signal of pulse length control.

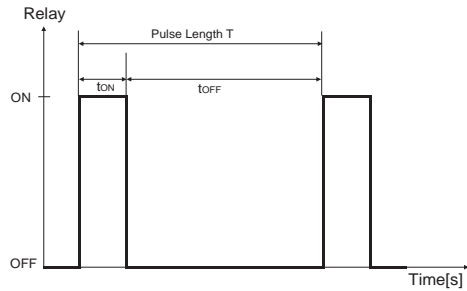

Control signal and pulse length control

Out put of relay controlled by hysteresis band is time. Crile T for open or close is constant.
 Different value comes from limited value, increase or decrease of open time is in accordance with proportion range.

Following applications:

$$t_{ON} + t_{OFF} = T \text{ (Const.)}$$

greater divergence \rightarrow greater t_{ON}

X_p exceeded $\rightarrow t_{ON} = T$ (relay remains picked up)

ACCESSORY 5 - ABBREVIATIONS IN FUNCTION FORM

Abbreviations	Indications
MEA	Measurement mode
CAL	Calibration mode
ENT	Confirmation
OFS	Zero point offset
SET	Set up
ATC	Automatic temperature compensation
SP1	Set point 1
SP2	Set point 2
LO	Low limit
HI	High limit
CNtr	Control
LIt	Limited point control
PLC	Pulse length control
RL3	Relay
OUT	Output signal
CONF	Configuration
CLE	Cleaning
GLAS	Glass electrode
ANTI	Antimony electrode
DEF	Default
CUR	Output current 1

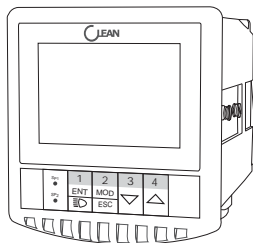

www.cleaninst.com

Manufacturer:

CLEAN Instruments - CISC

14656 Valley Blvd. City of Industry, CA 91746, U.S.